

# Hexagonal Magnetic Rollerball & Fountain Pen Kits Assembly

## Instructions

### Required Accessories:

- 7mm, Pen Mandrel
- Drill Bit 10.4 mm and 12.5mm(RZ-DB104, RZ-DB125)
- Bushing set
- Barrel Trimmer
- Live Tailstock Center
- 2 Part Epoxy Glue or Insta Cure (Cyanoacrylate) Glue
- Pen Blank: Minimum Size - 3/4" x 4-3/4"

### Preparing the Blank:

- Cut 2, 3/4" blanks to length of the tubes and add 1/16" for squaring off.
- Drill holes lengthwise through the blanks. (12.5mm Upper blank, 10.4mm for lower blank)
- Spread glue over the tubes, insert each tube with a twisting motion to spread the glue evenly inside. Center the tubes lengthwise inside the blanks.
- When the glue is dry, square the ends of the blanks. You can use a 7mm barrel trimmer with the proper sleeve, or a universal pen blank squaring jig with a power disc sander. Take the excess material down flush with the ends of the brass tube. (Do not trim beyond the length of the tube since this may interfere with operation of the mechanism and assembly).

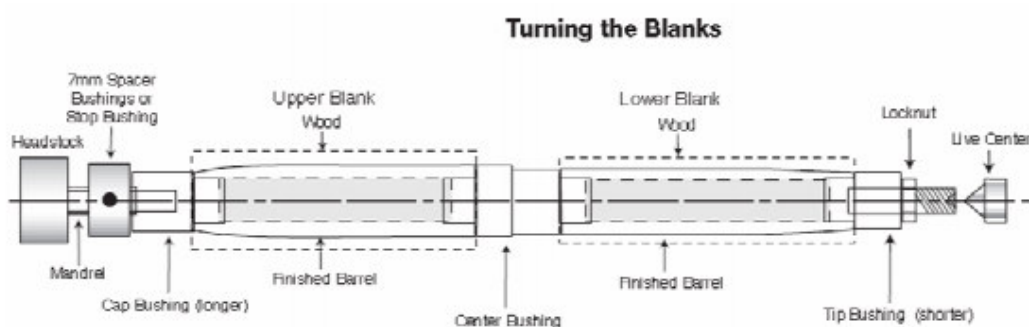

### Turning the Blank

- Mount the bushings and blanks according to the above diagram.
- Thread on the knurled nut and hand tighten to hold all components in place.
- Slide the tailstock up snugly against the mandrel shaft inserting the live center point into the mandrel dimple, lock in place.
- Hand tighten the quill adjustment to firm up the mandrel. (DO NOT

overtighten, it could damage the mandrel).

- Using sharp tools, turn the blank down close to the bushing diameter. Turn the barrel (straight or to a profile of your choice)
- Sand the blank down to be flush with the bushings gradually increasing the sandpaper grits.
- Finish the barrel with your choice of polish. Allow sufficient time for the polish to cure.

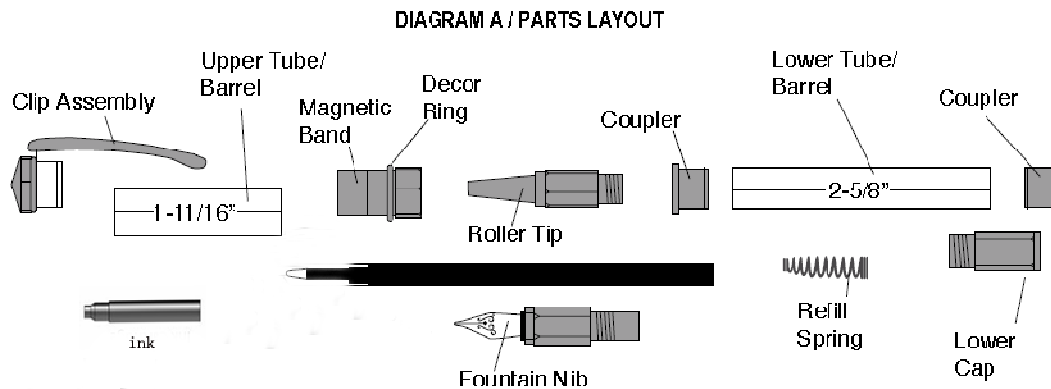

## Assembly

Layout parts according to diagram A.

- Press clip assembly into the smaller diameter of the upper barrel (shorter).
- Insert and press the magnetic band into the opposite end of the upper barrel.
- Insert each coupler into the ends of the lower barrel. Press in.
- Screw in the lower cap into either end of the lower barrel.
- **For Rollerball Pen:** Drop the spring. Wide end in first into the opening at the lower barrel. Drop the refill in, blunt end first. Screw the Roller tip into the coupler over the refill tip.
- **For Fountain Pen:** Attach either the ink cartridge or the refill pump into the back end of the nib.

Screw into the coupler at the lower barrel. To use the pump you will need an ink bottle.

Turn the knob counter clockwise until the piston inside the pump is at the bottom. Insert the nib into the bottle. Turn the knob clockwise. The ink will be drawn into the container of the pump.

For either pen, engage the ends of the pen. The magnet closure will keep the pen closed.

When writing, the cap will post over the lower barrel.